

CATHEDRAL

PRODUCT INFORMATION

Cathedral Architectural Cast Glass. Included in Nathan Allan's exclusive Freeform Series, Cathedral Architectural Cast Glass is one of 6 new "texture less" kiln formed glass designs. Texture-less designs are a first in our industry, and exclusively created by Nathan Allan. Inspired by ancestral Architecture, Cathedral is in our family of Linear Architectural patterns. Free-forming Flutes are created within this design, each at 1.5" (38mm) wide. Each flute is separated by a thin, continuous crease, which helps to define the individual flutes. The front convex surface of each flute provides an interesting 3-Dimensional design and privacy effect within this elegant linear design.

The back surface of our Cathedral Architectural Cast Glass is concaved, and also provides a unique appearance and privacy effect. Light will travel through the glass, enhancing the pattern details and amplifying the rich, black color. This Classic Architectural pattern is once again bringing life to historical designs.



MAXIMUM PANEL SIZE	FEET	METERS
Annealed or Tempered	5 x 10	1.5 x 3.0
GLASS TYPES / THICKNESS	3/8" 10 MM	1/2" 12 MM
Clear	•	•
Low Iron	•	•
Black	•	•
Bronze	•	•
Edgework	Machine flat polished	
Color Finishes	Lucent, Pearl	
Privacy Finishes	Frosted, Etched	
Safety	Tempered or Laminated	
Cleaning	Our glass products can be cleaned with liquid cleaners and paper towels, or soft clothes. Liquid cleaners with out ammonia will help reduce streaks on the glass. Avoid all abrasive cleaning materials.	
Flat Margins	Outside Vertical Edges – from 1/4" to 3/4" (6mm to 19mm). Interior Vertical Edges – 1/8" to 1/4" (4mm to 6mm)	
Pattern Details	If using 3/8" (10mm) thick flat glass, after pattern is formed, overall pattern thickness increases to 1/2" (12mm). Pattern thickness may vary , so allow 1/16" (2mm) variance. Front surface has a Convex shape, while back surface has a Concave shape. Individual flutes are 1.5" (38mm) wide	



CATHEDRAL GLASS PROFILE, SECTION VIEW

CATHEDRAL GLASS TOP | BOTTOM SECTION VIEW

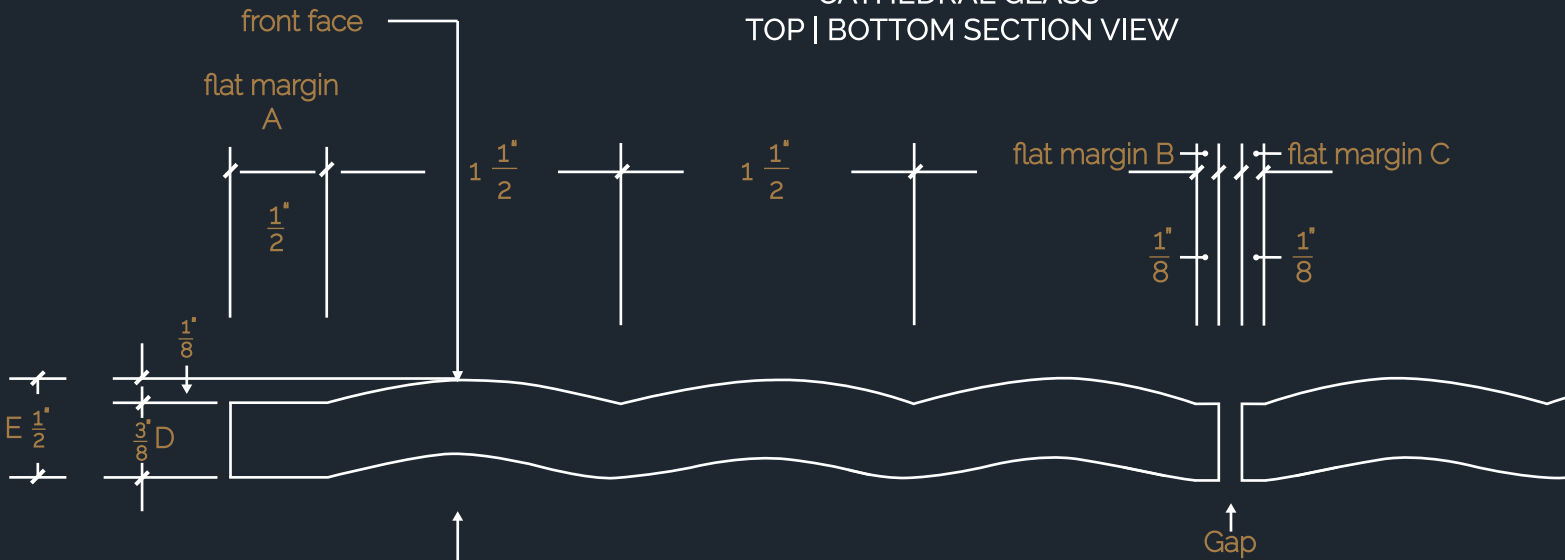

flat margin A – produced on the outside Vertical edge of panel, where glass is inserted into channel or molding. Outside flat margins will typically range from 1/4" to 3/4" wide

flat margins B + C – produced on the inside Vertical edges of panels, where panels are installed side x side. Inside flat margins will typically be 1/8" wide or less

D – indicates thickness of flat section of glass

E – indicates overall pattern thickness of glass

(Please note that the pattern thickness depth can vary slightly, from 1/16" to 1/8", on some panels)

CATHEDRAL GLASS TOP | BOTTOM SECTION VIEW

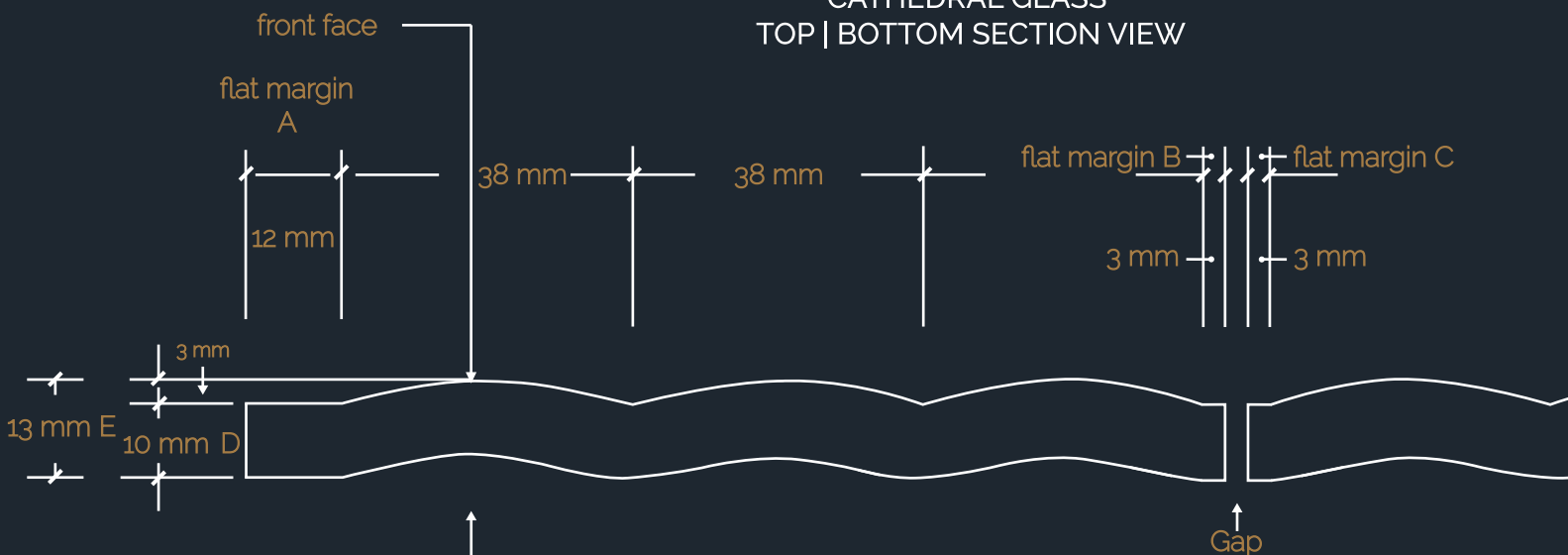

flat margin A – produced on the outside Vertical edge of panel, where glass is inserted into channel or molding. Outside flat margins will typically range from 6 mm to 19 mm wide

flat margins B + C – produced on the inside Vertical edges of panels, where panels are installed side x side. Inside flat margins will typically be 3 mm wide or less

D – indicates thickness of flat section of glass

E – indicates overall pattern thickness of glass

(Please note that the pattern thickness depth can vary slightly, from 2mm to 4mm, on some panels)